



OCEAN 90 NR

USER MANUAL

COLTRI SUB[®]
www.coltrisub.it
AEROTECNICA COLTRI S.p.A.

AEROTECNICA COLTRI S.p.A.
via Colli Storici 177 25010 San Martino della Battaglia
BRESCIA - ITALY
Tel: +39 030 99 103 01 +39 030 99 102 97
Fax: +39 030 99 10 283
www.aerotecnicacoltri.it coltrisub@coltrisub.it

PRECAUTIONS

WARNING: you should use the regulator only after you have passed a diving training centre that authorized to issue diving certificates. To use the regulator properly, the following precautions must be taken.

- The regulator must be used in strict compliance with the instructions set out in this manual.
- The regulator must be used only for the purposes indicated in this manual.
- The regulator must be serviced and repaired only by approved service centres at the regular intervals specified in the warranty. In order to ensure operating efficiency, use only manufacturer-approved spare parts.
- If the above conditions are not complied with the responsibility for any faults lies with the owner or user of the regulator.

APPLICATIONS

All regulators of Aerotecnica Coltri® S.p.A. have two stages. The first stage uses a piston or a diaphragm and the second one uses an inlet valve. The first stage is connected to the second stage by a low-pressure hose. In two-stage regulators the high-pressure air in the cylinders is reduced in the first stage to about 10 Bar above ambient pressure. Ambient pressure varies according to diving depth. The air that reaches the second stage is immediately available to the inlet valve but is supplied only when the diver breathes slightly.

WARNING: the regulator that are the subject on this manual is certified for use in dives down to a maximum depth of 50 metres.

PRELIMINARY CHECKS

Before each dive, check all the regulator functions and check the parts of wear. If faults are found, do not use the regulator but get it checked by an approved service centre. Connect the first stage of the regulator to the cylinder using the fitting system that is appropriate for the cylinder valve: a standard yoke assembly or a DIN screw connector for the cylinders using a DIN valve. With yoke assembled, the O-ring seal is positioned on the cylinder's valve. With a DIN connector the O-ring seal is positioned at the end of the connecting system. Check the O-ring for wear and replace it if necessary.

USE

Before opening the cylinder valve, try to breathe in through the second stage mouthpiece. If it is impossible to do so the inlet valve and the exhaust diaphragms are working correctly. If leaks occur, do not dive and contact a specialised service centre. Slowly open the cylinder valve and try to breath in through the mouthpiece of the second stage, press the exhaust button of the middle of the cover of the second stage. The regulator must regain its balance without leaks. Any air leaks mean that the regulator is not working correctly and must be repaired.

WARNING: EN 250/A1:2006 : The regulator complies with the standard EN250 but is not designed for more than one user simultaneously. If the regulator is configured and used by more than one user at the same time, its water and breathing performances might not be compliant with the requirements of the standard EN250.

COLD WATER DIVING

Avoid using the regulator in water below + 10° C. You must also have been awarded a certificate in cold-water diving before using the regulator. If the regulator is used in water below 0° C do not use the regulator out of the water.

MAINTENANCE

All regulators of Aerotecnica Coltri® S.p.A. are made from material that is suitable for use in seawater and each parts is protected from oxidation and has been approved for continuous use over many years. The regulators should nevertheless be tested every year at specialist centre.

CLEANING

After use, use the air left in the cylinder to dry the protective cap, to prevent water entering in the first stage. Protect the sintered filter by covering it with the protective cap and rinse out the regulator with fresh water (not under pressure).

WARNING: during rising, do not press the manual purge bottom of the second stage to prevent water from entering through the inlet valve. Leave the regulator to dry in a dry place but do not expose to direct sunlight. Place it in a temperature that is protected from high temperatures and make sure that the low-pressure hose that connects the first stage to the second stage uses a curve radius of at least 150 mm.

LUBRICATION

Only the O-rings require occasional lubrication. They must be lubricated with silicone oil and greases.

WARNING: under no circumstances use normal (non-silicone) oils because they could damage the regulator parts. Do not use silicone lubricants for silicone parts (diaphragm, mouthpiece, valve seat plug) because such lubricants would cause irreparable damage.

Do not use alcohol or solvents to clean plastic or rubber components.

Ocean 90 NR 1st stage

TECHNICAL FEATURES

CERTIFIED CE EN 250 2000

Type : Balanced diaphragm.

Materials :

Body : Drawn brass copper plated, nickel-plated, chromium plated.

Yoke : Drawn forging brass, nickel-plated, chromium plated.

Diaphragm : Rubber

Spring : Stainless-steel.

Plating treatment :

Chrome plated.

Weight without hose :

INT 230 Bar 822 gr

DIN 230 Bar 658 gr

Ports : 2 HP, 4 LP

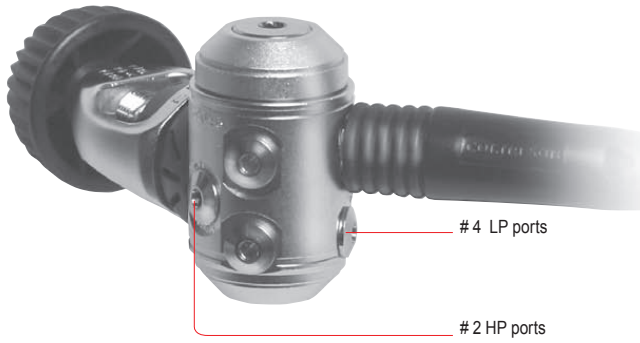

1st stage with DIN 230 Bar type.

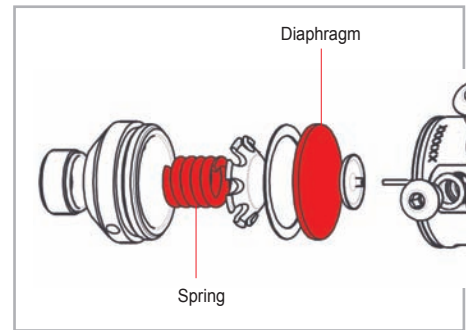

Ocean 90 NR 2nd stage

TECHNICAL FEATURES

CERTIFIED CE EN 250 2000

Materials:

Body : High resistance Polycarbonate.

Diaphragm : Silicone

Control lever : Stainless-steel.

Exhaust diaphragms : Silicone.

Mouthpiece : Silicone

Spring : Stainless-steel.

Hose length : 28.7"

Weight without hose : 186 gr

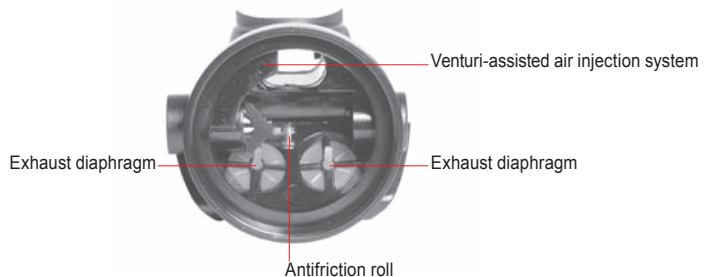

Ocean 90 NR 1st stage

- 1 - Slide bar D.25031
- 2 - Clips holder filter
- 3 - Return spring system
- 4 - Adjusting spring
- 5 - INT conical filter
- 6 - Yoke
- 7 - Locking Yoke
- 8 - LP 3/8 plug
- 9 - LP 7/16 plug
- 10 - 1st stage ring diaphragm for regulation
- 11 - Locking O-ring
- 12 - Balancing chamber for MF4
- 13 - 1st stage plug
- 14 - Thrust washer
- 15 - Pilot boss
- 16 - Body MF4
- 17 - Poppet
- 18 - 1st stage "Compact" seating
- 19 - Plug holder INT
- 20 - Diaphragm washer hold
- 21 - Ring nut
- 22 - Ring holder
- 23 - R1st stage diaphragm
- 24 - BK Anties 1st stage diaphragm
- 25 - Wing nut
- 26 - OR. 2012 70-75 SH Ø2.9 x Ø1.78
- 27 - OR. 108 70 SH Ø8.73 x Ø1.78
- 28 - OR. 2031 SH Ø7.66 x Ø1.78 70 SH
- 29 - OR. 2037 70 SH Ø9.25x Ø1.78
- 30 - OR. 2056 70 SH Ø14x Ø1.78
- 31 - OR. 3050 90SH Ø12.37x Ø2.62

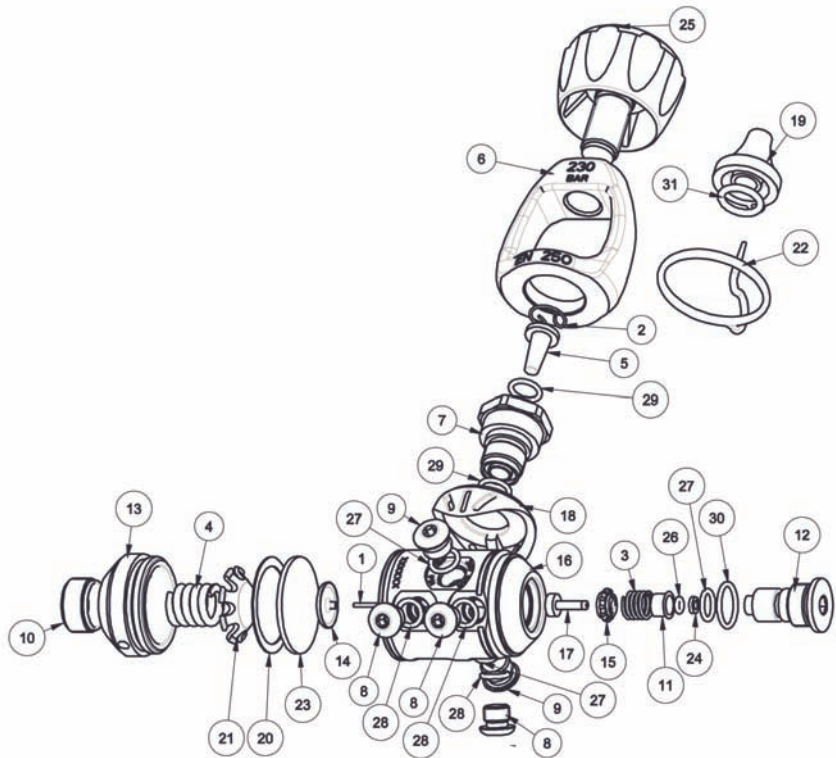

Ocean 90 NR 2nd stage

- 10 - Manual regulation system
- 11 - Conical spring
- 12 - Chamber
- 13 - Nylon ring
- 14 - Silicone diaphragm
- 15 - Body
- 16 - Exhaust valve
- 17 - Silicone mouthpiece
- 18 - Nylon clam
- 19 - Hose-connector
- 19/a - Metering orifice
- 20 - O Ring
- 21 - Silicone shaft pad
- 22 - Valve seat
- 23 - Nut shaft
- 24 - Spacing bar
- 25 - Washer shaft
- 26 - Shaft
- 27 - Spring shaft
- 28 - Control lever valve
- 28/a - Needle for lever
- 50 - Hose
- 52 - O-ring hose connector

